

## Description

This type is a maintainable thermodynamic steam trap. The 662 is specifically designed for relatively small condensate loads and therefore is ideal for mains drainage applications.

Note: The Integral Blow-down valve is an assembly designed to be fitted to 662 Thermodynamic steam traps as an extra option.

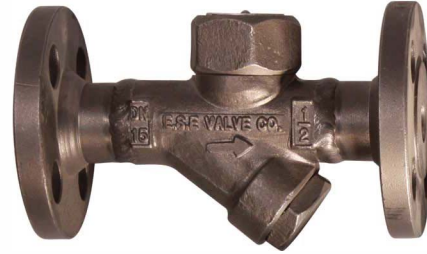

## Limiting Conditions

Maximum Body Design Conditions	PN63
PMO - Maximum Operating Pressure	42 kgf/cm <sup>2</sup>
TMO - Maximum Operating Temperature	400 °C
PMOB – Maximum Operating Back Pressure - not exceed	75% of Inlet Pressure
Minimum Operating Differential Pressure for Satisfactory Operation	1 kgf/cm <sup>2</sup>
PMA - Maximum Allowable Pressure	63 kgf/cm <sup>2</sup>
TMA - Maximum Allowable Temperature	400 °C
Cold Hydraulic Test Pressure	95 kgf/cm <sup>2</sup>

## Operating Range

ΔPMX – Maximum differential pressure 42 kgf/cm<sup>2</sup>

## Sizes and Pipe Connections

1/2", 3/4" and 1" Flanged (ANSI B16.5)

## Dimensions / Weights (Approximate) mm and kg

Size	A	B	Flanged					
			150#		300#		600#	
			C	Weight	C	Weight	C	Weight
1/2"	75	80	150	2	160	2.5	170	3
3/4"	80	90	150	3	160	3.5	170	4
1"	85	90	160	4	170	4.5	180	5

Constructions are a bit different according the sizes.

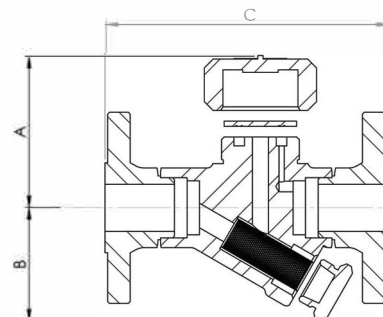



E.S.E. Valve Co. Ltd.

021 66479486  
0912 8448763

فروش

E.S.E. Valve Co.

## Flanged Thermodynamic Steam Traps – 662

### Materials

No.	Part	Material
1	Body	AISI 420
2	Disc *	AISI 420
3	Cap	AISI 420
4	Strainer Screen *	AISI 304/316
5	Strainer Cap	AISI 420
6	Flange	ASTM A105
7	Name Plate	ALUMINUM
8	Blow-Down Cap **	AISI 420
9	Blow-Down Screw **	AISI 420

Note: (\*) Spare Part

(\*\*) Optional extra

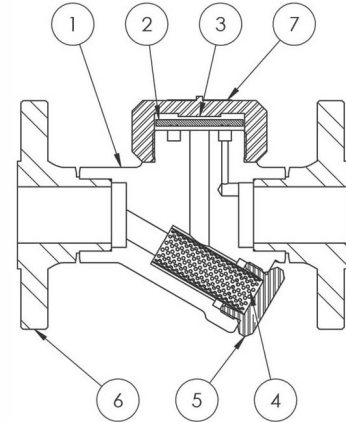

### Capacities

Maximum continual discharge amount (kg/h)

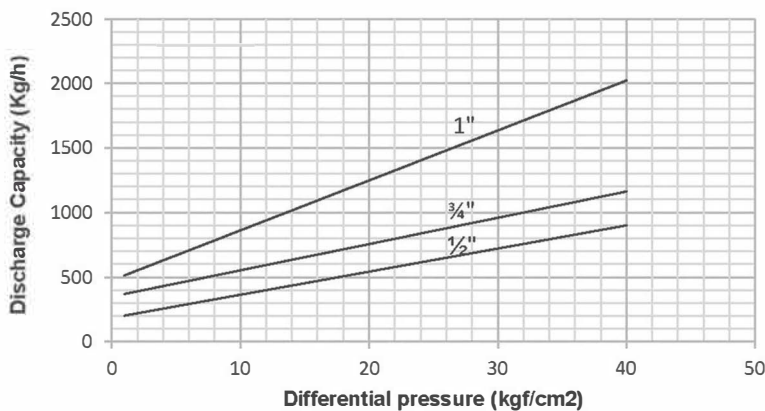

### Installation

The trap should preferably be installed in the horizontal plane, with a small drop leg preceding it. Where the trap discharges into a closed return system, a non-return valve should be fitted downstream to prevent return flow. Ensure all connection ports are clear from obstruction. Always open isolation valves slowly until normal operating conditions are achieved. This will avoid system shocks. Check for leaks and correct operation. Always ensure the correct tools, safety procedures and protective equipment is used at all times.

### How to Order

Example: TD662 1/2", Flanged Thermodynamic Steam Trap with Blow-down Valve.